

RECURSO LIMITED

HONG KONG DIPLOMA OF SECONDARY EDUCATION MOCK EXAMINATION 2026

DESIGN AND APPLIED TECHNOLOGY PAPER 1

Technology, Design and Society

Question-Answer Book

8:30 am – 10:30 am (2 hours)

This paper must be answered in English

INSTRUCTIONS

- (1) After the announcement of the start of the examination, you should first write your Candidate Number in the space provided on Page 1 and stick barcode labels in the spaces provided on Pages 1, 3, 5 and 7.
- (2) Answer Question 1 in Section A and any two questions from Section B. Write your answers in the spaces provided in this Question-Answer book. Do not write in the margins. Answers written in the margins will not be marked.
- (3) Supplementary answer sheets will be supplied on request. Write your Candidate Number, mark the question number box and stick a barcode label on each sheet, and fasten them with string **INSIDE** this book.
- (4) No extra time will be given to candidates for sticking on the barcode labels or filling in the question number boxes after the 'Time is up' announcement.
- (5) All dimensions, unless otherwise specified, are in millimetres (mm).
- (6) Use your own judgement for any dimensions not given.

©迴享有限公司 共享創意授權
Recurso Limited 2025
CC BY-NC 4.0

Please stick the barcode label here.

Candidate Number

撥款資助
FUNDED BY



創新計劃項目
INNOVATIVE PROGRAMME

IMPACT
INNOVATION
LAB 創效實現室

協創機構
INTERMEDIARY



印刷贊助
PRINTING SPONSOR

FINGERPRINT
Your Print Solution Partner



* A 1 8 0 E 0 0 1 *

Section A – Compulsory question

1. Design a multifunctional walking aid for elderly users

Elderly individuals often need to walk a certain distance during daily outings, such as going to the market or visiting a clinic. Due to weaker physical strength and reduced balance, they require both walking support and a way to rest whenever needed. Design a multifunctional walking aid that assists elderly users in walking safely, resting, and carrying personal items.

The design of the walking aid should fulfil the following requirements:

- <Requirement 1>: It should have four wheels and height-adjustable handles to accommodate elderly users of different body heights and standing elbow heights.
- <Requirement 2>: The overall structure must be foldable. After folding, its volume must be reduced to at least half of its original size.
- <Requirement 3>: It should include a single seat equipped with a safety belt.
- <Requirement 4>: It should include a storage compartment with a capacity large enough to contain an object measuring at least 300 mm × 150 mm × 200 mm.

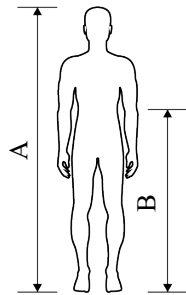

	Range
Height (A)	1550 - 1750
Standing elbow height (B)	900 - 1100

- (a) (i) Write one design consideration related to its mechanical property and one related to its physical property when selecting a material for manufacturing the frame of the walking aid. Suggest a material that meets both requirements. (3 marks)

Mechanical property:

Physical property:

Material:

- (ii) Based on <Requirement 1>, state one safety consideration for the wheel part and one for the handle part of the walking aid and explain how they enhance user safety. (4 marks)

	Safety consideration	How it enhances user safety
Wheel Part	<hr/> <hr/>	<hr/> <hr/>
Handle Part	<hr/> <hr/>	<hr/> <hr/>

Answers written in the margins will not be marked.

Answers written in the margins will not be marked.

Answers written in the margins will not be marked.

Please stick the barcode label here.

- (b) Based on <Requirement 1> to <Requirement 4>, propose **two** preliminary design ideas for the walking aid which use different folding methods. Using annotated sketches, sketch the forms of the walking aid when it is in use and after folding. Indicate the positions of the major folding parts and the folding methods. (12 marks)

Idea 1



Form when in use

Form after folding

Idea 2



Form when in use

Form after folding

Answers written in the margins will not be marked.

Answers written in the margins will not be marked.

Answers written in the margins will not be marked.

Answers written in the margins will not be marked.

- (c) Based on the considerations in (a) and the preliminary design ideas in (b), develop a final design idea for the multifunctional walking aid. Using annotated sketches, complete the following tasks: (16 marks)
- ① show the appearance and structure of the walking aid in use, including its pictorial drawing, front, plan, and end elevations;
 - ② indicate and explain the design features that fulfil <Requirement 1> to <Requirement 4>;
 - ③ Label the overall dimensions of the walking aid.

Answers written in the margins will not be marked.

Answers written in the margins will not be marked.

Please stick the barcode label here.

Based on your final design idea in (c), answer (d), (e) and (f).

(d) Based on <Requirement 1>, using annotated sketches, show: (7 marks)

- ① the operating principle of the handle height adjustment mechanism;
- ② how the design fulfils the requirement of the user group's body height and standing elbow height.

Answers written in the margins will not be marked.

Answers written in the margins will not be marked.

Answers written in the margins will not be marked.

(e) Based on <Requirement 2>, using annotated sketches, show:

(12 marks)

- ① the operating procedures for folding the walking aid, its appearance after folding, and its overall dimensions when folded;
- ② the design details of the major components used for folding and stabilising the structure, both in use and when folded.

Answers written in the margins will not be marked.

Answers written in the margins will not be marked.

Answers written in the margins will not be marked.

Please stick the barcode label here.

(f) Based on <Requirement 3>, using annotated sketches, show: (6 marks)

- ① the procedures for fastening and unfastening the safety belt by the elderly user;
- ② an additional safety-enhancing feature that can reduce the risk of head injury if the elderly user is seated on the chair and the walking aid tips over.

Answers written in the margins will not be marked.

Answers written in the margins will not be marked.

Answers written in the margins will not be marked.

Section B - Attempt any two questions in this section.

2. Figure 1 shows a conceptual diagram of a battery-powered electric jar opener. Figure 2 shows three operating states of the opener during use.

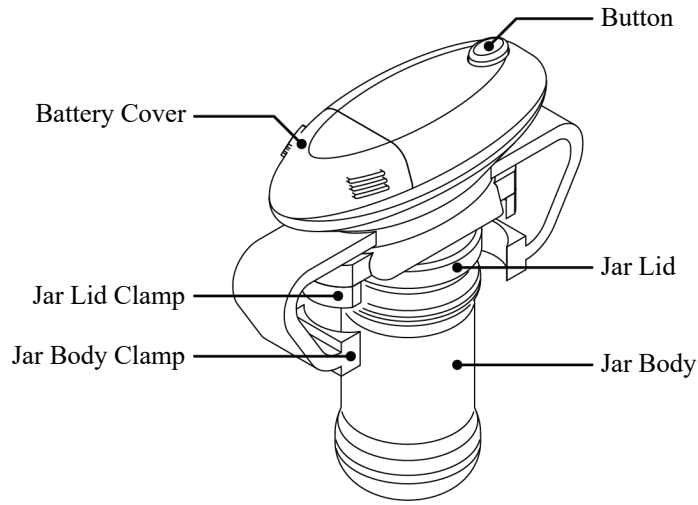

Figure 1

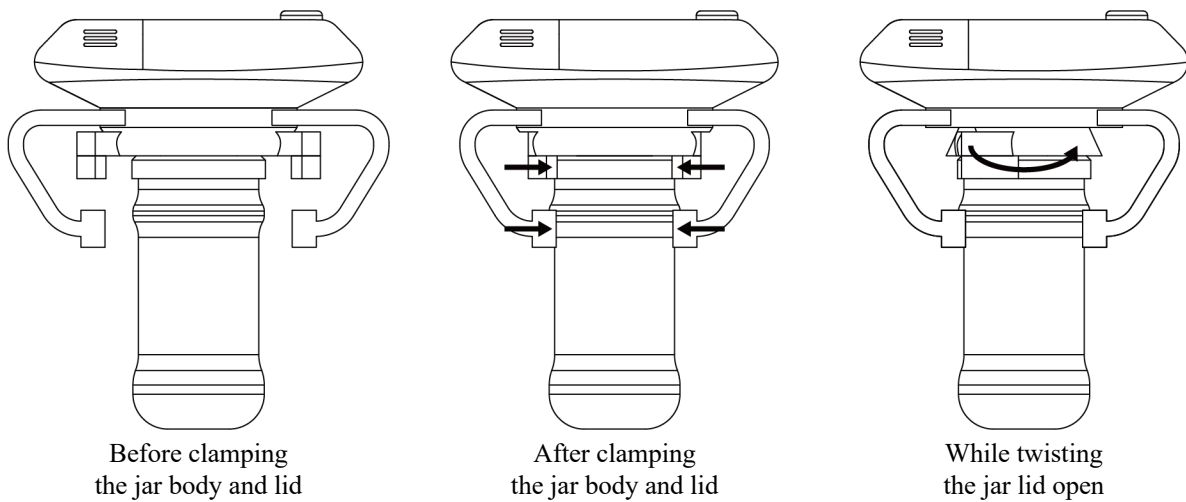

Figure 2

- (a) The jar lid clamp and jar body clamp are driven by the same motor and are mechanically linked to operate together, allowing the bottle body and lid to be clamped simultaneously. Name the mechanism and, using annotated sketches, show the operational principle of the mechanism. (4 marks)

Mechanism:

Annotated sketches:

Answers written in the margins will not be marked.

Answers written in the margins will not be marked.

Answers written in the margins will not be marked.

Answers written in the margins will not be marked.

- (b) After the bottle lid has been clamped, another motor uses a mechanism to deliver high torque and drive the lid clamp to rotate, thereby opening the lid. Name the mechanism and, using annotated sketches, show the operational principle of the mechanism. (4 marks)

Mechanism:

Annotated sketches:

- (c) The electric jar opener now includes a light emitting diode. State the reason for adding the light emitting diode and explain how the light emitting diode works in coordination with the operation of the jar opener. (2 marks)

Reason for adding:

How it works together:

- (d) The figure below shows the incomplete circuit diagram of the electric jar opener. Add electrical symbols in the dotted boxes to complete the circuit and fill in the names of components P and Q in the table below. (4 marks)

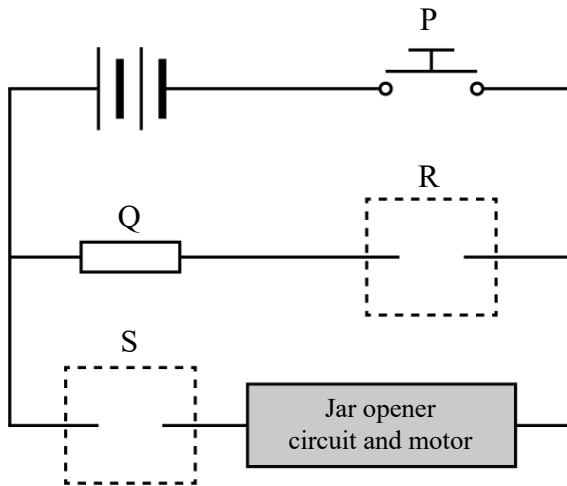

Component	Name
P	
Q	
R	Light emitting diode
S	Diode

- (e) Write **two** ergonomic considerations of the electric jar opener. (2 marks)

Answers written in the margins will not be marked.

Answers written in the margins will not be marked.

Answers written in the margins will not be marked.

- (f) The developer has applied for both a patent and a registered design for the electric jar opener. Specify one aspect protected under the patent and one aspect protected under the registered design. (2 marks)

Patent:

Registered design:

- (g) Write one design approach that can enhance the sustainability of the electric jar opener and explain your answer. (2 marks)

Answers written in the margins will not be marked.

Answers written in the margins will not be marked.

3. The figures below show the pictorial view and the side view of an outdoor fitness equipment.

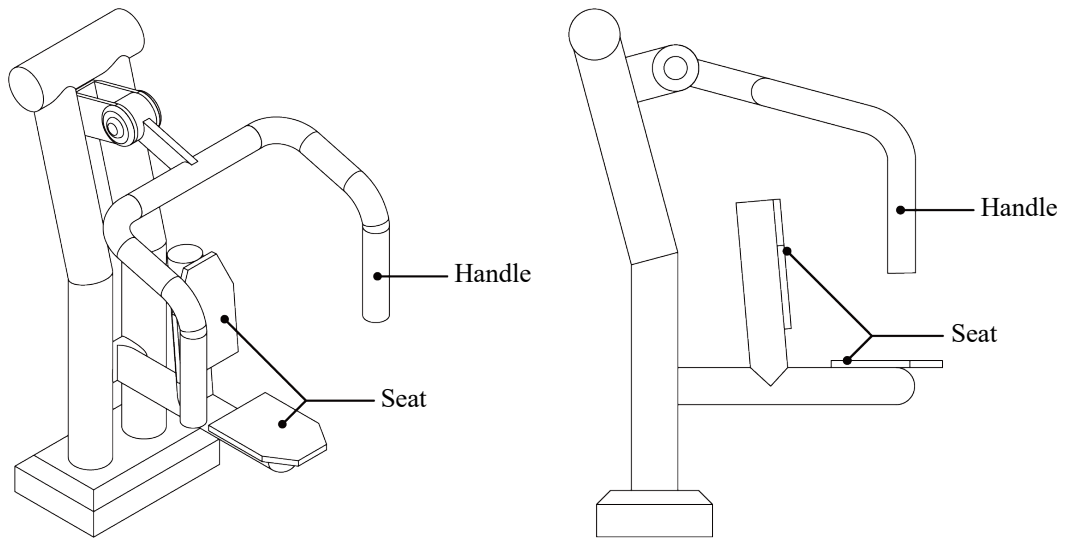

- (a) State the class of lever of this outdoor fitness equipment, and show the position of the fulcrum, as well as the positions and directions of effort and load in the end elevation below. (4 marks)

Class of lever:

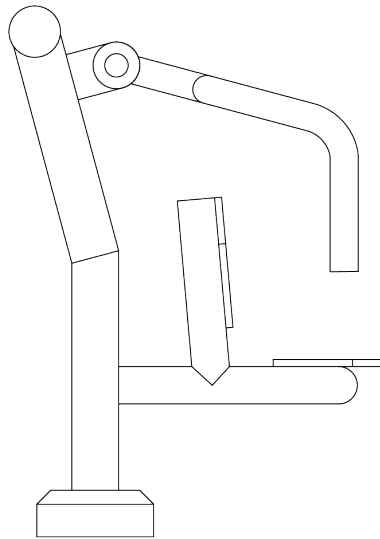

- (b) Using annotated sketches, show an improved design of the fitness equipment handle that allows the user to grip it more easily, and explain why the new design is easier to hold. (3 marks)

Answers written in the margins will not be marked.

Answers written in the margins will not be marked.

Answers written in the margins will not be marked.

- (c) Using annotated sketches,
- (i) Show an improved design of the outdoor fitness equipment that allows the user to increase the load during use; (3 marks)
 - (ii) Users can adjust the load according to their individual needs. (2 marks)

- (d) Using annotated sketches, show how the load-bearing structure of the outdoor fitness equipment seat can be reinforced to enhance safety during use. (4 marks)

- (e) (i) The outer casing of the outdoor fitness equipment is printed with the following symbol. Write one meaning of this symbol. (1 mark)



- (ii) The company that manufactures this outdoor fitness equipment is considering applying for an additional International Organization for Standardization (ISO) certification for the product. State one advantage of obtaining an additional ISO standard for the product. (1 mark)

Advantage: _____

- (f) The market demand for outdoor fitness equipment mainly comes from housing estates and government projects. From the perspective of production cost, explain why this type of equipment is generally manufactured in batch production rather than mass production. (2 marks)

Answers written in the margins will not be marked.

4. The figures below show two types of roll-type paper towel dispensers. Figure 1 is a sensor-activated dispenser, while Figure 2 is a manual push-type dispenser.

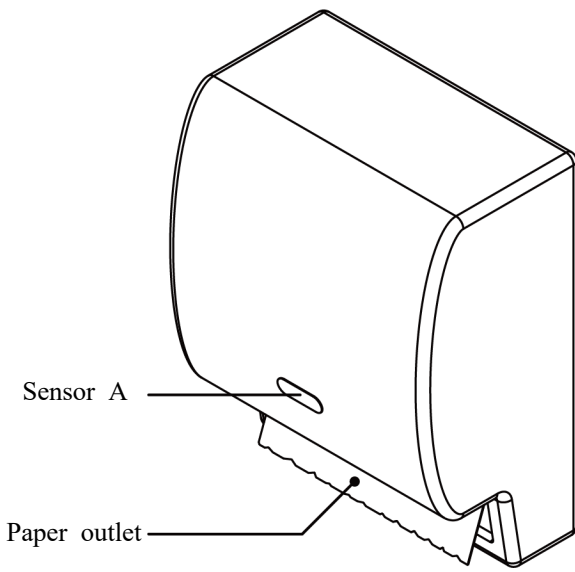

Figure 1

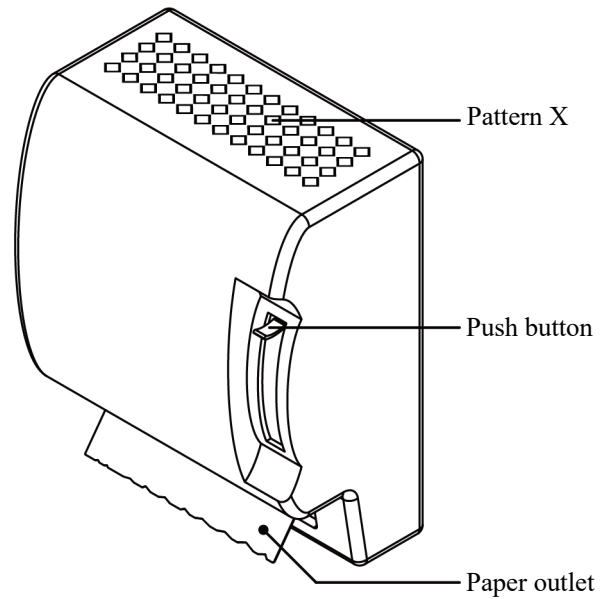

Figure 2

- (a) Write an advantage for each type of paper towel dispenser. (2 marks)

Sensor-activated:

Manual push-type:

- (b) The sensor-activated dispenser will only dispense paper when both of the following conditions are met:
 ① A user's hand is detected in front of the dispenser ② There is still paper remaining inside the dispenser.
 (i) Write the logic gate that is used in the sensor-activated dispenser and draw its symbol. (2 marks)

Logic gate:

Logic gate symbol:



- (ii) Complete the following truth table to show the operating logic of the paper towel dispenser. (3 marks)

Hand detected (Detected = '1')	Paper remaining (No remaining paper = '0')	State of paper dispensing (On = '1')
0	0	0

Answers written in the margins will not be marked.

Answers written in the margins will not be marked.

- (c) The sensor-activated paper towel dispenser will automatically dispense one sheet when Sensor A detects the user's hand. Even if the hand remains in the sensing area, the dispenser will still dispense only one sheet. The hand must be removed and then placed back into the sensing area for the dispenser to release another sheet. Complete the following simplified flowchart (① to ⑤) of the dispenser. (5 marks)

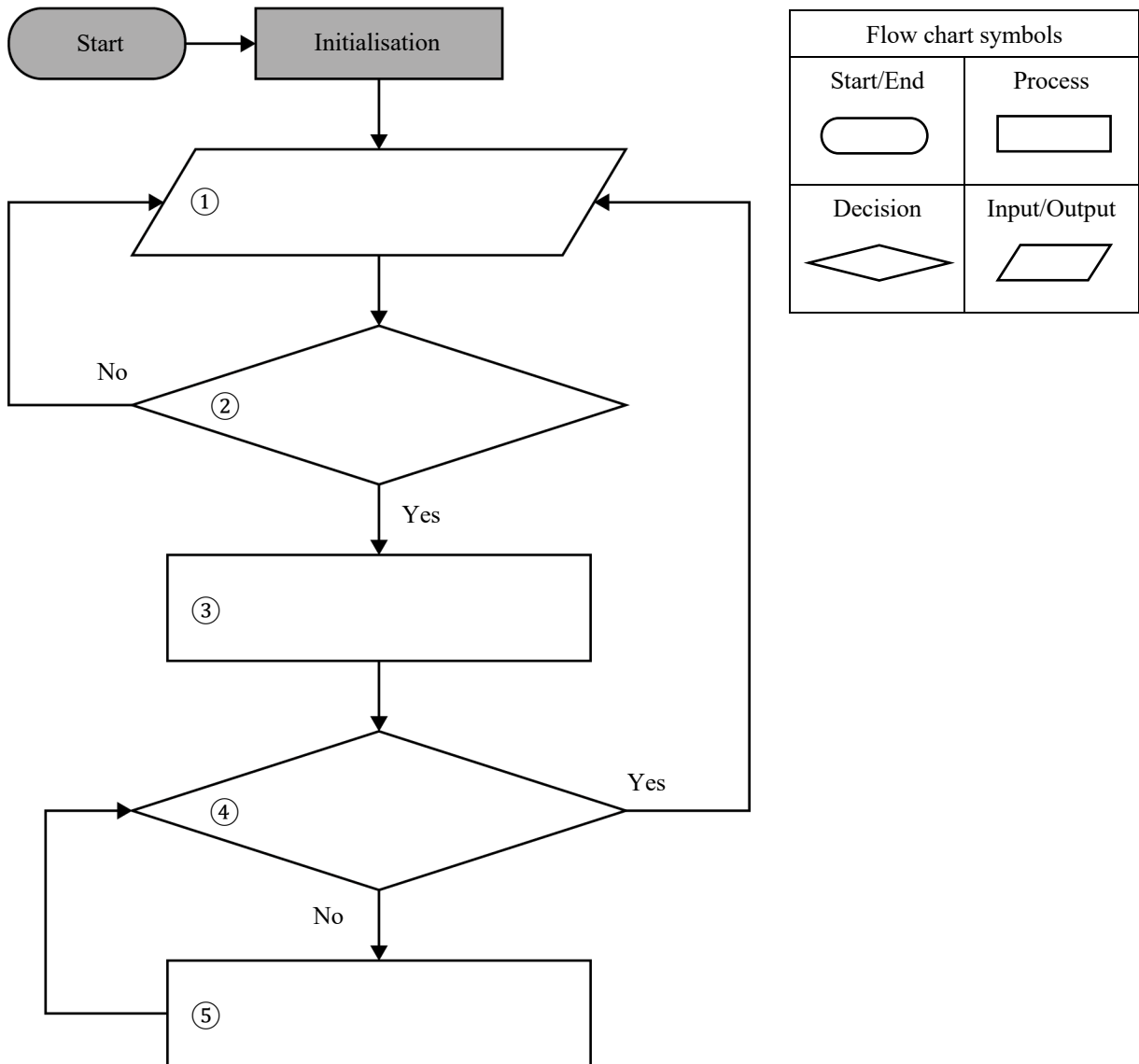

Answers written in the margins will not be marked.

Answers written in the margins will not be marked.

- (d) Suggest a suitable type of sensor to be used as Sensor A for detecting whether the user's hand is within the designated area, and state two considerations when setting up Sensor A. (3 marks)

Type of sensor:

Consideration ①:

Consideration ②:

- (e) Referring to Figure 2, state one design principle of Pattern X. (1 mark)

Design principle:

Answers written in the margins will not be marked.

- (f) Using annotated sketches, show an improved design of the manual push-type paper towel dispenser that allows the user to tear off one sheet more easily, and explain why the new design makes tearing easier. (3 marks)

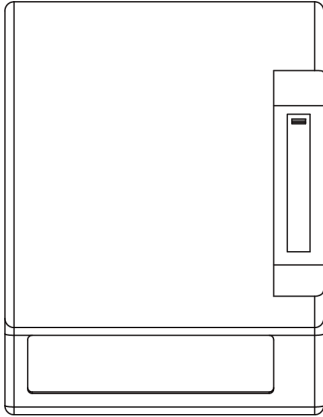

- (g) State one 'environmentally friendly production' method that can be adopted when manufacturing a paper towel dispenser. (1 mark)

END OF PAPER

Sources of materials used in this paper will be acknowledged on the official website of Recurso (recurso.com.hk) at a later stage.

Answers written in the margins will not be marked.

Answers written in the margins will not be marked.

Answers written in the margins will not be marked.

Do not write on this page.

Answers written on this page will not be marked.